

SNAP D-Series Racks

Features

- Ideal for discrete control applications
- Control directly or through an Opto 22 PC adapter card
- Use panel or DIN-rail mounting
- Modules snap into place

Description

SNAP D-series racks are designed for discrete control applications and can accommodate 4, 6, 8, or 12 SNAP 4-channel digital modules. These racks use an industry-standard 50-pin header connector, which allows these racks to be used in a variety of applications.

The logic side of the I/O circuitry can be controlled directly or by using an Opto 22 PCIe-AC5 (PCI Express bus), PCI-AC5 (PCI bus) or G4AC5 or AC5 (ISA bus) PC adapter card.

In addition, the 4-module-position **SNAP-D4M** can be used with:

A Raspberry Pi® and Opto 22's Digital I/O Carrier Board for Raspberry Pi (part number [OPTO-P1-40P](#))

Opto 22's Classic brain boards, which use one of Opto 22's industry-standard protocols (*mistic*®, *Optomux*®, or *Pamux*®) to control the I/O and communicate either serially or in parallel

Field devices are wired directly to the top-mounted removable connectors on the SNAP I/O modules. The module and rack design allows modules to simply "snap" on and off the mounting rack.

SNAP racks use a retention-rail locking system that holds modules securely to the rack. Use two 4-40 by ½-inch standard machine screws to secure each module in position.

All SNAP racks offer panel mounting and the option of DIN-rail mounting. SNAP racks use a single 5 VDC power source.

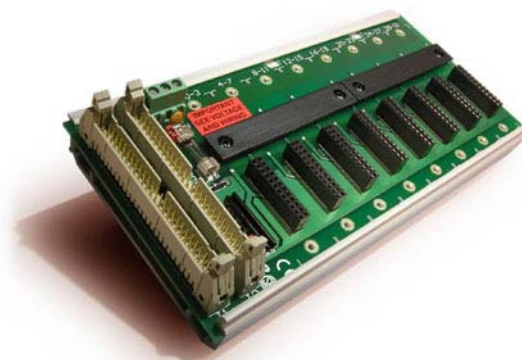

SNAP-D8M Rack

Part Numbers

Part	Description
SNAP-D4M	4-module digital I/O rack
SNAP-D6M	6-module digital I/O rack
SNAP-D8M	8-module digital I/O rack
SNAP-D12M	12-module digital I/O rack
SNAP-CDBBDIN	Classic digital brain board DIN rail adapter
SNAP-FUSE1AB	1 amp fuse, 25-pack
SNAP-TEX-DRC10	SNAP PAC rack DIN-rail adapter clip, 10-pack
SNAP-TEX-REC10N	Narrow end cap for SNAP PAC racks DIN-rail assemblies, 10-pack

SNAP D-Series Racks

Specifications: SNAP-D4M (4 Module Position)

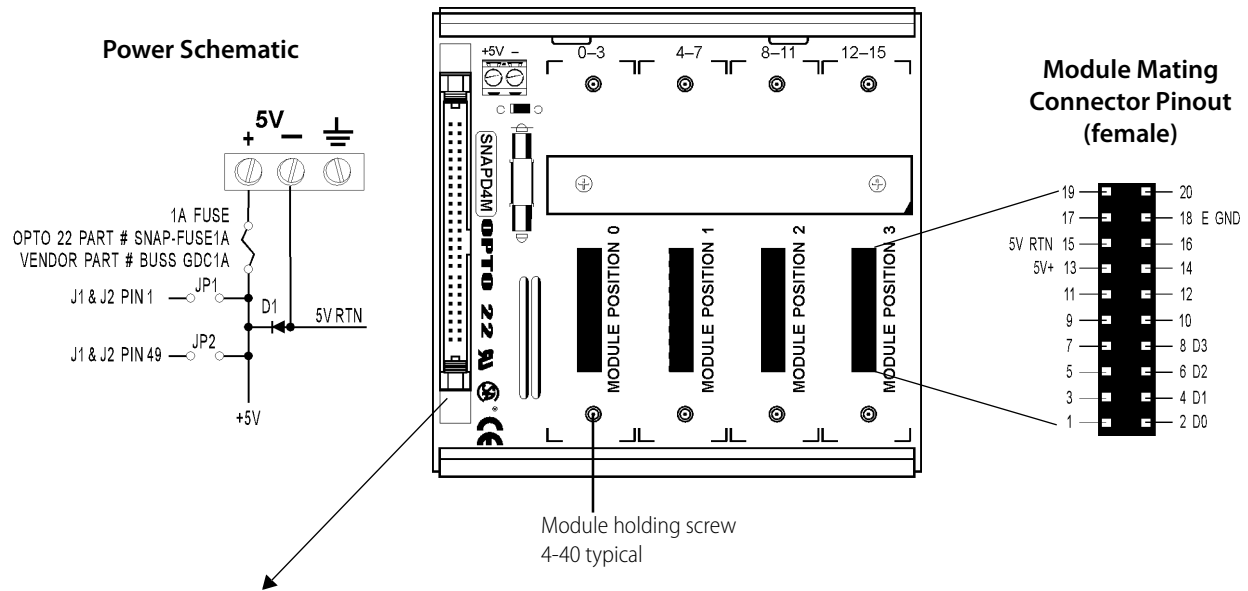

Control Connector (50-pin male)

Module Position	Channel Position	J1 Control Connector
0	0	47
	1	45
	2	43
	3	41
1	4	39
	5	37
	6	35
	7	33
2	8	31
	9	29
	10	27
	11	25
3	12	23
	13	21
	14	19
	15	17

Operating Requirements

Power Requirements	5 VDC ± 0.1 VDC @ 200 mA max. (700 mA with brain board)
Operating Temperature Range	0° to 70°C
Relative Humidity	95%, non-condensing

Notes:

1. Even pins on control connectors are connected to 5V RTN.
2. Pin 1 of control connectors J1 and J2 is connected to +5V through jumper JP1.
3. Pin 49 of control connectors J1 and J2 is connected to +5V through jumper JP2.
4. For operation with PC adapter cards (PCIe-AC5, PCI-AC5, AC5, or G4AC5), remove jumpers JP1 and JP2.
5. Odd numbered pins 3 through 15 of control connectors are not used.

SNAP D-Series Racks

Specifications: SNAP-D6M (6 Module Position)

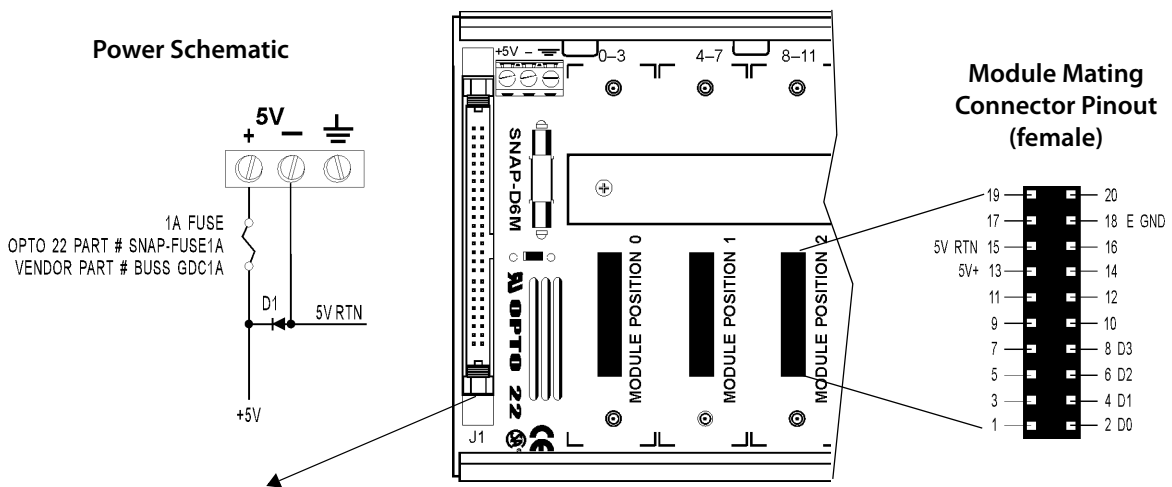

Control Connector (50-pin male)

Module Position	Channel Position	J1 Control Connector
0	0	47
	1	45
	2	43
	3	41
1	4	39
	5	37
	6	35
	7	33
2	8	31
	9	29
	10	27
	11	25
3	12	23
	13	21
	14	19
	15	17
4	16	15
	17	13
	18	11
	19	9
5	20	7
	21	5
	22	3
	23	1

Operating Requirements

Power Requirements	5 VDC \pm 0.1 VDC @ 300 mA max.
Operating Temperature Range	0° to 70°C
Relative Humidity	95%, non-condensing

Notes:

1. Even pins on control connectors are connected to 5V RTN.
2. SNAP-D6M and SNAP-D12M are designed to interface with PC adapter cards (PCIe-AC5, PCI-AC5, AC5, or G4AC5). They are not compatible with brain boards, because there is no power to the control connector.
3. Pin 49 - "no" connection.

SNAP D-Series Racks

Specifications: SNAP-D8M (8 Module Position)

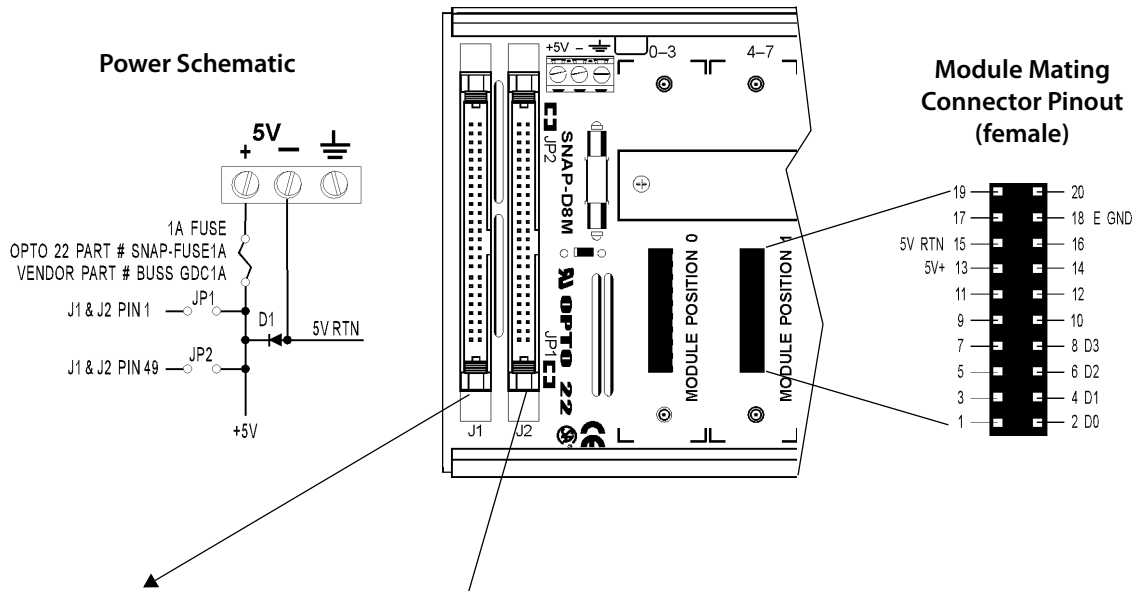

Control Connectors (50-pin male)

Module Position	Channel Position	J1 Control Connector
0	0	47
	1	45
	2	43
	3	41
1	4	39
	5	37
	6	35
	7	33
2	8	31
	9	29
	10	27
	11	25
3	12	23
	13	21
	14	19
	15	17

Module Position	Channel Position	J2 Control Connector
4	16	47
	17	45
	18	43
	19	41
5	20	39
	21	37
	22	35
	23	33
6	24	31
	25	29
	26	27
	27	25
7	28	23
	29	21
	30	19
	31	17

Operating Requirements

Power Requirements	5 VDC ± 0.1 VDC @ 400 mA max.
Operating Temperature Range	0° to 70°C
Relative Humidity	95%, non-condensing

Notes:

- Even pins on control connectors are connected to 5V RTN.
- Pin 1 of control connectors J1 and J2 is connected to +5V through jumper JP1.
- Pin 49 of control connectors J1 and J2 is connected to +5V through jumper JP2.
- For operation with PC adapter cards (PCIe-AC5, PCI-AC5, AC5, or G4AC5), remove jumpers JP1 and JP2.
- Odd numbered pins 3 through 15 of control connectors are not used.

SNAP D-Series Racks

Specifications: SNAP-D12M (12 Module Position)

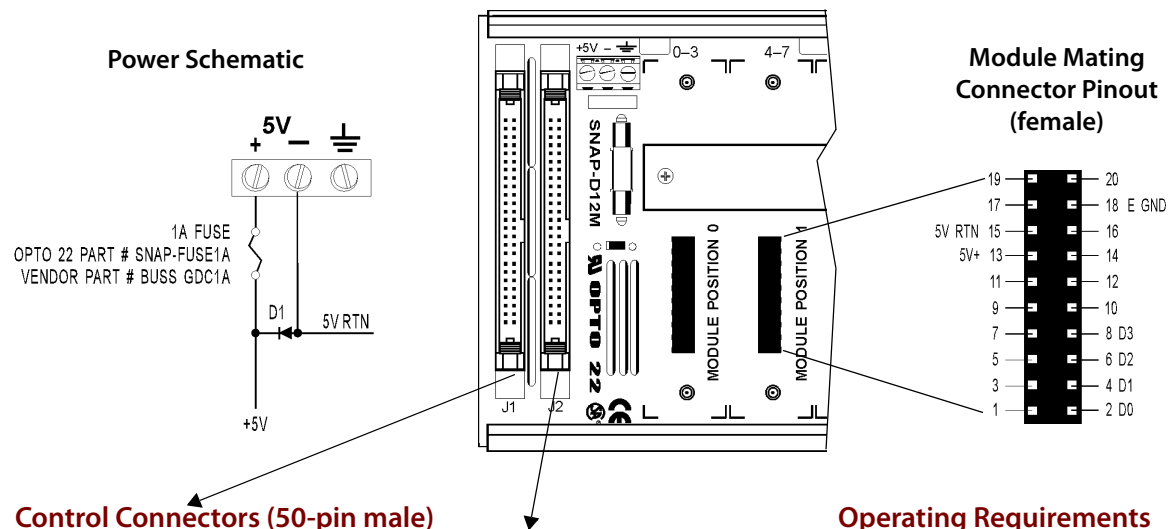

Control Connectors (50-pin male)

Module Position	Channel Position	J1 Control Connector
0	0	47
	1	45
	2	43
	3	41
1	4	39
	5	37
	6	35
	7	33
2	8	31
	9	29
	10	27
	11	25
3	12	23
	13	21
	14	19
	15	17
4	16	15
	17	13
	18	11
	19	9
5	20	7
	21	5
	22	3
	23	1

Module Position	Channel Position	J2 Control Connector
6	0	47
	1	45
	2	43
	3	41
7	4	39
	5	37
	6	35
	7	33
8	8	31
	9	29
	10	27
	11	25
9	12	23
	13	21
	14	19
	15	17
10	16	15
	17	13
	18	11
	19	9
11	20	7
	21	5
	22	3
	23	1

Operating Requirements

Power Requirements	5 VDC \pm 0.1 VDC @ 1200mA max.
Operating Temperature Range	0° to 70°C
Relative Humidity	95%, non-condensing

Notes

1. Even pins on control connectors are connected to 5V RTN.
2. SNAP-D6M and SNAP-D12M are designed to interface with PC adapter cards (PCIe-AC5, PCI-AC5, AC5, or G4AC5). They are not compatible with brain boards, because there is no power to the control connector.

SNAP D-Series Racks

Dimensional Drawing

Front View (when Mounted)—All Models

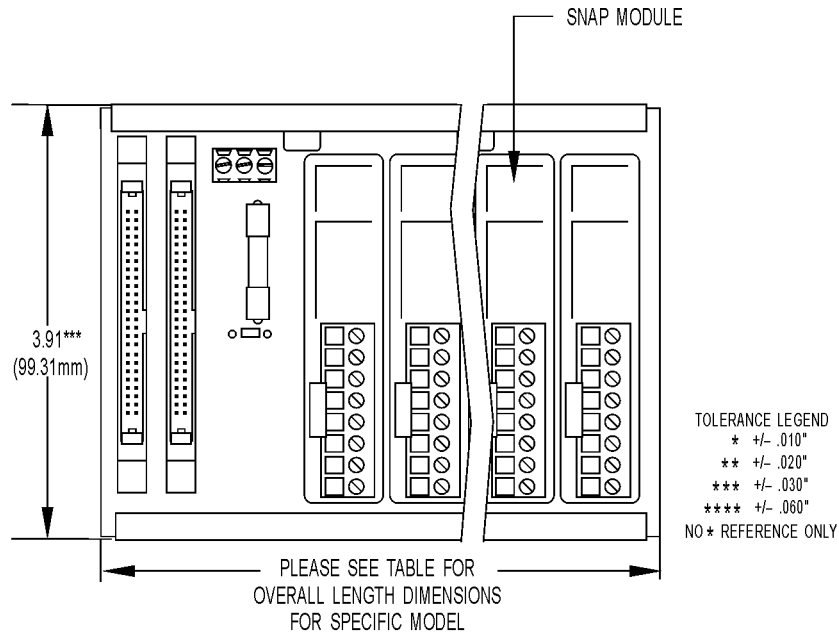

Overall Length Dimension (All Models)

Part Numbers	Description	Length (inches)	Length (mm)
SNAP-D4M	4-module rack	4.19	106.43
SNAP-D6M	6-module rack	5.74	145.8
SNAP-D8M	8-module rack	7.74	196.6
SNAP-D12M	12-module rack	10.74	272.8

SNAP D-Series Racks

Dimensional Drawing

Right Side View (with Customer-supplied DIN-Rail Option)—All Models

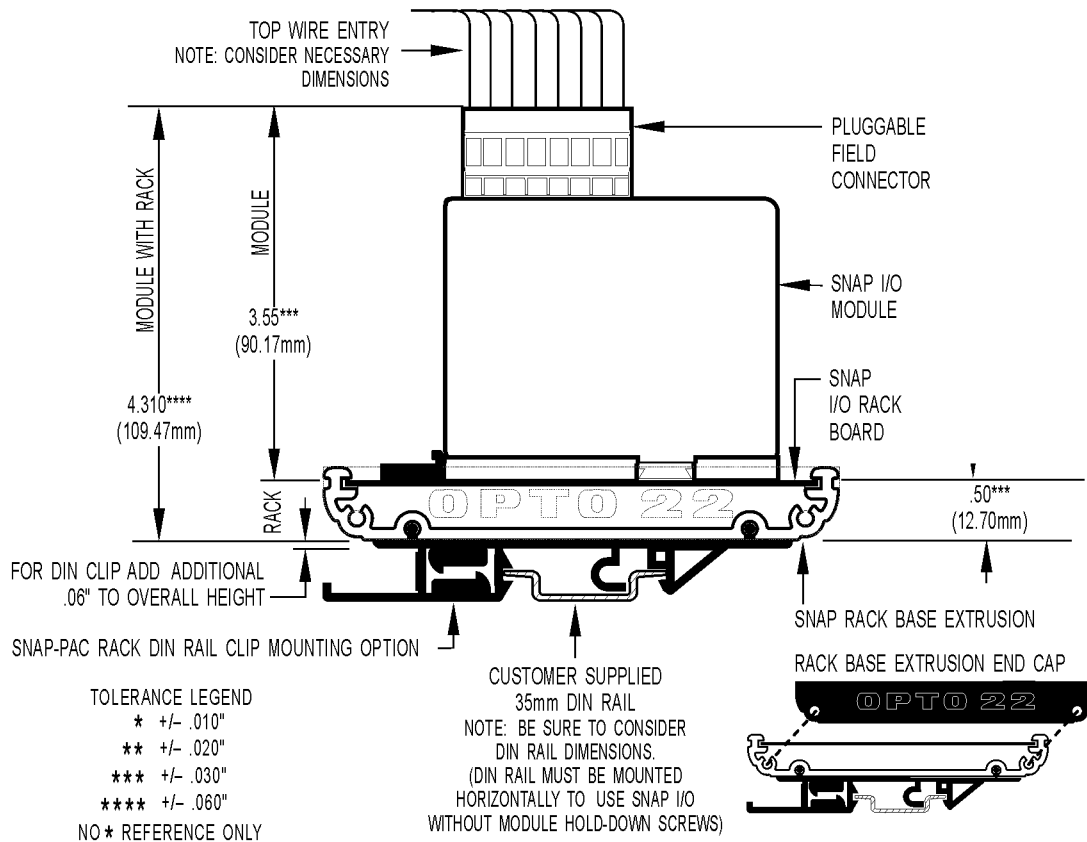

Dimensional Drawing

Typical Plain View of SNAP Mounting Extrusion—All Models

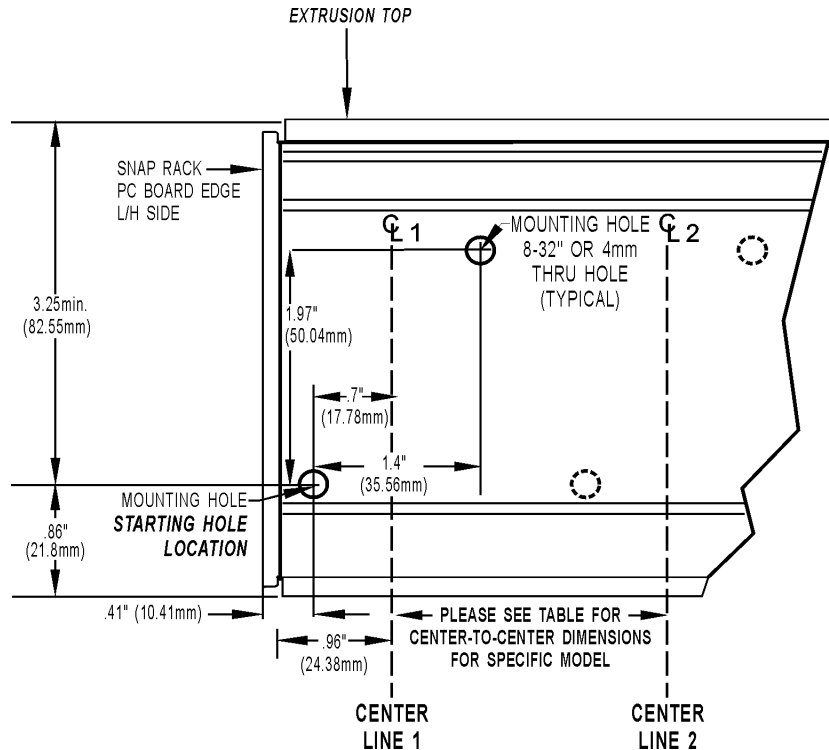

General Mounting Instructions

The SNAP rack assembly should be mounted horizontally, as shown in diagram, if not using module hold-down screws.

Preferred Method: Template (product on site)

1. Use SNAP rack mounting extrusion as template.
2. Be sure to use drawing to determine required product and option clearances.

Alternate Method: Prefabrication of Panels (no product on site)

1. Mounting holes are in sets of two located on lower left and upper right, with respect to a centerline (CL).
2. Using the drawing, determine CL1 mounting hole positions. (CL1 is located on the left side of all SNAP rack mounting extrusions.)
3. Use the center-to-center length specification table to determine offset between centerlines and number of centerline positions for each model.
4. Repeat process for each centerline position.
5. Dimensions shown in drawing apply to all models.

Center-to-Center Length (All Models)

Part Numbers	Description	Center-to-Center Length (inches)	# of Center Positions
SNAP-D4M	4-module rack	1.98	2
SNAP-D6M	6-module rack	3.53	2
SNAP-D8M	8-module rack	5.53	2
SNAP-D12M	12-module rack	4.26	3

More About Opto 22

Products

Opto 22 develops and manufactures reliable, easy-to-use, open standards-based hardware and software products deployed worldwide.

Industrial automation, process control, building automation, industrial refrigeration, remote monitoring, data acquisition, Industrial Internet of Things (IIoT), and information technology applications all rely on Opto 22.



groov

Monitor and control your equipment from anywhere using your smartphone or tablet with groov. Build your own mobile app easily—just drag, drop, and tag. No programming or coding. Visit groov.com for more information and your free trial.

SNAP PAC System

Developer- and IIoT-ready, the SNAP PAC System connects physical assets to databases and applications using open standards. The SNAP PAC System consists of four integrated components:

- SNAP PAC controllers
- PAC Project™ Software Suite
- SNAP PAC brains
- SNAP I/O™

{RESTful API}



SNAP PAC Controllers

SNAP PAC programmable automation controllers handle a wide range of digital, analog, and serial functions for data collection, remote monitoring, process control, and discrete and hybrid manufacturing.

For IIoT applications and easier integration with company systems, standalone and rack-mounted SNAP PACs include a built-in HTTP/HTTPS server and **RESTful API** (application program interface). The REST API gives you secure, direct access to I/O and variable data using your choice of programming languages. No middleware, protocol converters, drivers, or gateways needed.

Based on open Ethernet and Internet Protocol (IP) standards, SNAP PACs make it easier to build or extend a system without the expense and limitations of proprietary networks and protocols.

PAC Project Software Suite

Opto 22's PAC Project Software Suite offers full-featured, cost-effective control programming, HMI (human machine interface), OPC server, and database connectivity software.

Control programming includes both easy-to-learn flowcharts and optional scripting. Commands are in plain English; variables and I/O point names are fully descriptive.

PAC Project Basic offers control and HMI tools and is free for download on our website, www.opto22.com. PAC Project Professional, available for separate purchase, adds one SoftPAC software-based controller, OptoOPCServer, OptoDataLink, options for controller redundancy or segmented networking, and support for legacy Opto 22 serial *mistic*™ I/O units.

SNAP PAC Brains

While SNAP PAC controllers provide central control and data distribution, SNAP PAC brains provide distributed intelligence for I/O processing and communications. Brains offer analog, digital, and serial functions, including thermocouple linearization, local PID loop control, watchdog, totalizing, and much more.

SNAP I/O

I/O provides the local connection to sensors and equipment. Opto 22 SNAP I/O offers 1 to 32 points of reliable I/O per module. Analog, digital, and serial modules are mixed on one mounting rack and controlled by a SNAP PAC brain or rack-mounted PAC.

Quality

Founded in 1974, Opto 22 has established a worldwide reputation for high-quality products. All are made in the U.S.A. at our manufacturing facility in Temecula, California.

Because we test each product twice before it leaves our factory, rather than only testing a sample of each batch, we can guarantee most solid-state relays and optically isolated I/O modules for life.

Additional support is always available on our website: how-to videos, OptoKnowledgeBase, self-training guide, troubleshooting and user's guides, and OptoForums.

In addition, hands-on training is available for free at our